

**SAV 434.05**

**PRECISION ANGLE DRESSERS**

For angled dressing of grinding wheels



**APPLICATION**

For precise grinding wheel dressing using the sinusoidal principle on surface grinding machines.

**DESIGN**

All parts hardened HRC 60 and precision-ground.  
The starting position of the dressing unit is at 45°.  
Angle accuracy: 5 arc sec

**ACCESSORIES**

Dressing diamonds for SAV 434.05 - 45:  
SAV 401.01 - K 10  
Dressing diamond for SAV 434.05 - 100:  
SAV 401.01 - MK 1  
Available subject to a surcharge.

**APPLICATION**

The desired angle is adjusted with gauge blocks as per a supplied table (sinusoidal principle).



SAV 434.05 - 45  
Dressing travel: 45 mm

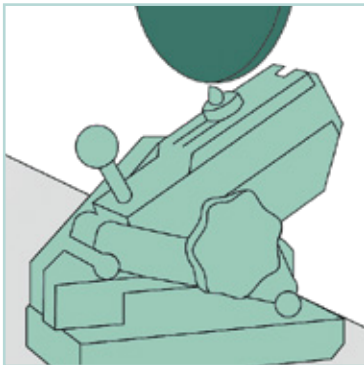

SAV 434.05 - 100  
Dressing travel: 100 mm

Max. dressing travel A	in mm	45	100
Base area B x C	in mm	140 x 70	245 x 78
Height D - E	in mm	142 - 172	232 - 302
Slide width F	in mm	40	48
Home position	in °	45	45
Total adjustment range	in °	0 - 90	0 - 90
Axis distance G	in mm	100	200
∅ for dressing diamond	in mm	6.2 / 1:10	MK 1
Weight	in kg	4.75	13.5

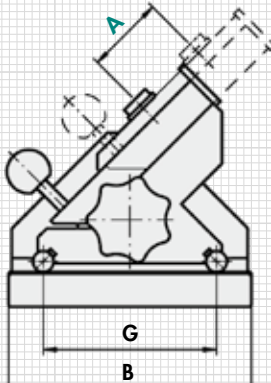
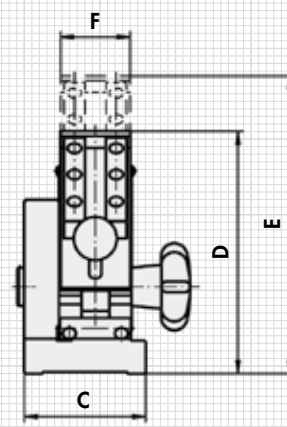
**ORDERING EXAMPLE**

**Designation** SAV no. - max. dressing travel

Precision angle dresser SAV 434.05 - 100