

**SAV 434.06****PRECISION SIDE DRESSER**

For dressing the side faces of grinding wheels

**APPLICATION**

For dressing the side faces on grinding wheels, for penetration of slots, adjustment range 0.5 to 50 mm.

**DESIGN**

Manufactured from tool steel, hardened HRC 60. Available with (K) or without (N) cooling system on request.

**ACCESSORIES**

Dressing diamond SAV 401.01 - 08, available subject to a surcharge.



Side dressing unit SAV 434.06 - K,  
with cooling system

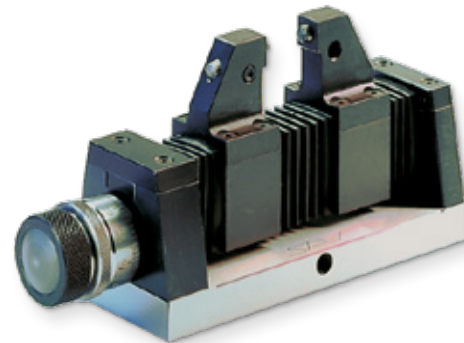
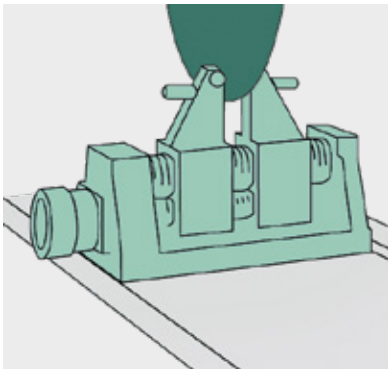

Side dressing unit SAV 434.06 - N,  
normal version without cooling system

Base area	in mm	190 x 72
Height	in mm	115
Adjustment range	in mm	0,5 - 50
Max. grinding wheel width	in mm	50
Feed per rotation	in mm	1
Feed per scale division	in mm	0,01
Opening for diamond	in mm	8
Weight	in kg	5,0

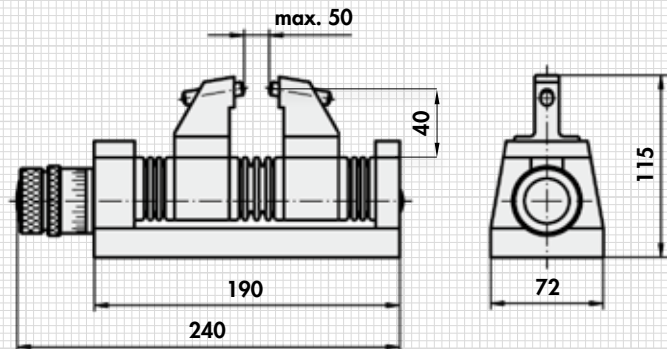
**ORDERING EXAMPLE**

Designation	SAV no. - version
Precision side dresser	SAV 434.06 - K