

SAV 241.29

ELECTRO HOLDING MAGNETS

Flat design

APPLICATION

Due to the extremely low height, these chucks are primarily used in handling applications. The magnet is active when switched on and is used for holding ferromagnetic workpieces. To achieve the rated holding force, the steel surfaces of the contact side must be fully covered by the workpiece.

DESIGN

The chucks consist of an electro magnetic holding system. Depending on the area of application, the applicable accident prevention regulations must be observed. For devices of protection class 1, the user must ensure the PE connection as per VDE 0100 par. 6.

TECHNICAL DATA

The technical information (chapter 1.4) must be observed when using the devices.

- Rated voltage: 24 V DC
- Duty cycle: 100 % duty cycle
- Protection rating: IP 65 (as per DIN 40050)
- Insulation material class: E

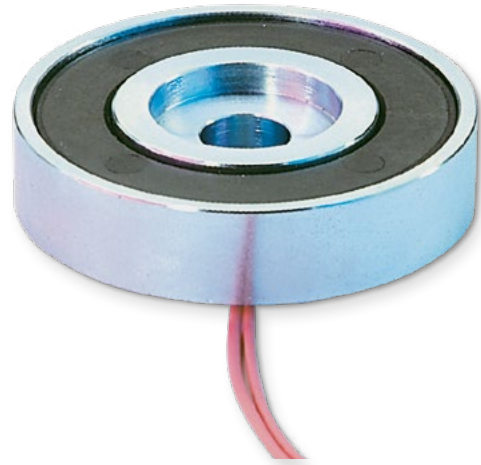

INFORMATION ON TECHNICAL DATA:

The max. holding forces are stated for steel 1.0037 and refer to the optimum workpiece thickness with an air gap of $\delta L = 0$ mm and 100 % coverage of the contact surface. The values are listed for 90 % rated voltage and at operating temperature (approx. 60 K overtemperature without additional heat dissipation). If different conditions apply to the application, the rated holding force is reduced (see Technical information, chapter 1.4). For safety reasons, a safety factor should be used depending on the application. The table values for the rated capacity are maximum values for determining the electrical accessory parts and refer to 20 °C excitation winding temperature at rated voltage (VDE 0580/10.70 § 9.1). During operation, the rated power reduces depending on the proportional duty cycle. The chuck is fastened from the front using cheese-head screws.

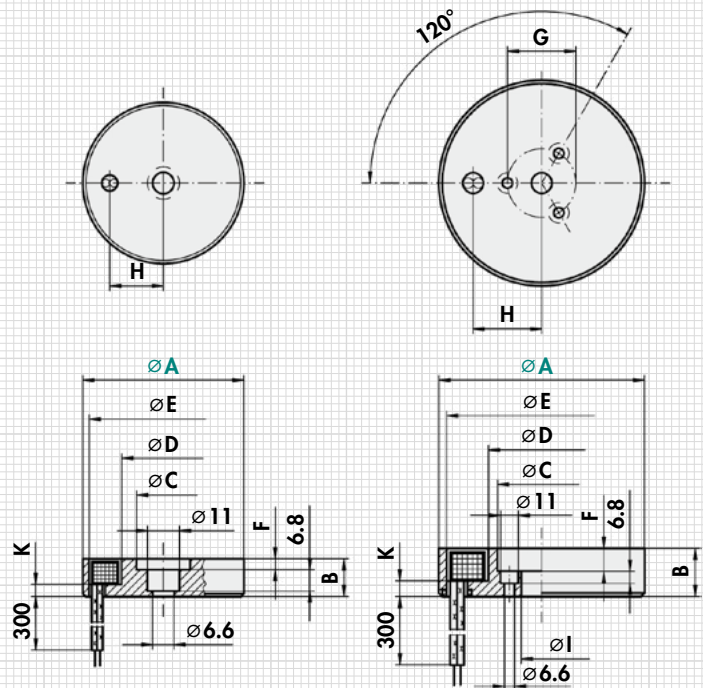

SAV 241.29 - 56

SAV 241.29 - 110 and -170

mm										N	mm		W	kg
A	B	C	D	E	F	G	H	I	K	Rated holding force	Optimum coverage thickness	Power	Weight	
56 ^{+0.1} _{-0.3}	13	23	32	51.5	4	-	23.5	-	3.7	750	>4.0	7.1	0.17	
110	21	53.5	65.3	103.5	10	40	49.2	26	5.5	2050	>6.0	14.7	0.90	
170	29	90.7	110.3	158	19	76	76.4	60	9.0	5000	>10.0	31.4	3.00	

ORDERING EXAMPLE

Designation	SAV no. - A
Electro holding magnet	SAV 241.29 - 170