

SAV 241.32

ELECTRO MAGNETIC BARS

With high holding forces

APPLICATION

Type C devices are suitable for holding parts with flat surfaces, while type D devices can be used for parts with uneven or scaled surfaces. To achieve the rated holding force, the steel surfaces of the contact side must be fully covered by the workpiece.

DESIGN

The electro magnetic bar chucks are direct-current workholding systems. The magnet is active when switched on and is used for holding ferromagnetic workpieces. Tapped holes are provided on the underside for fastening. 2 easily accessible screws inside the device are provided for the electrical connection. In addition, a PG gland is provided for attaching a strain-relieved cable. This gland can be screwed in either from the side or from underneath. When working with electromagnetic bar chucks, the corresponding accident prevention regulations must be observed depending on the application.

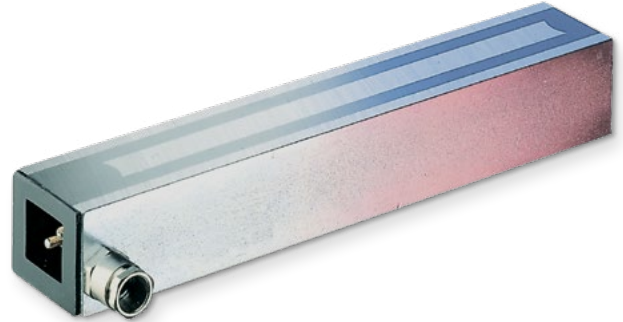

TECHNICAL DATA

- Rated voltage: 24 V DC
- Insulation material class: E
- Protection rating: Device IP 53 (as per DIN 40050 connection IP 00)
- Duty cycle: 100 % duty cycle

INFORMATION ON TECHNICAL DATA:

The table values for the rated capacity are maximum values for determining the electrical accessory parts and refer to 20 °C excitation winding temperature at rated voltage (VDE 0580/10.70 § 9.1). During operation, the rated power reduces depending on the proportional duty cycle. The pole pitch and its influence on the action principle is described in the technical information. The max. holding forces FH are provided for steel 1.0037 and refer to a plate thickness of > 8 mm for type C and > 10 mm for type D. The forces are listed for an air gap $\delta_L = 0$ mm and 100 % coverage of the contact surface, 90 % of the rated voltage and at operating temperature (approx. 50 K overtemperature without additional heat dissipation). If different conditions apply to the application, the rated holding force is reduced (see Technical information, chapter 1.4). For safety reasons, a safety factor should be used depending on the application.

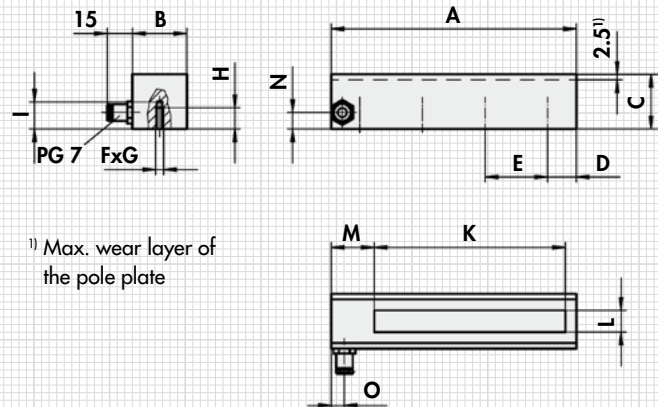

Type and size	mm															Pole step	Rated holding force	Rated power	kg
	A	B	C	D	E	F	G	H	I	K	L	M	N	O					
C 01	101.5	32	31	20	50	2	M 6	10	13.5	68.0	10	23.5	12	8.5	16	880	7	0.65	
C 02	151.5	32	31	20	50	3	M 6	10	13.5	118.0	10	23.5	12	8.5	16	1500	10.5	0.88	
C 03	201.5	32	31	20	50	4	M 6	10	13.5	168.0	10	23.5	12	8.5	16	2100	14	1.22	
C 04	401.5	32	31	20	50	8	M 6	10	13.5	368.0	10	23.5	12	8.5	16	4700	25	2.48	
C 05	501.5	32	31	20	50	10	M 6	10	13.5	468.0	10	23.5	12	8.5	16	6000	35	3.15	
C 06	601.5	32	31	20	50	12	M 6	10	13.5	568.0	10	23.5	12	8.5	16	7200	42	3.75	
D 07	151.5	60	49	30	75	2	M 8	12	15.0	93.5	12	36.5	18	10.0	30	2600	22	2.35	
D 08	201.5	60	49	35	120	2	M 8	12	15.0	143.5	12	36.5	18	10.0	30	3750	31	3.20	
D 09	501.5	60	49	35	140	4	M 8	12	15.0	443.5	12	36.5	18	10.0	30	10400	70	9.20	

ORDERING EXAMPLE

Designation SAV no. - type and size
 Electro magnetic bar SAV 241.32 - D 09