



The magnetic chuck features a high magnetic power, sturdy design and a long service life. The pole pitch forms "true" N and S poles.



### DESIGN

- Solid pole plate with 13 mm, 18 mm or 25 mm transverse pole pitch
- "True" N/S pole spacing
- With water cooling for increased accuracy on request
- With compressed air holes for easier removal of large parts (adhesion) for  $P = 18\text{ mm}$  or  $25\text{ mm}$  on request
- Pole plates bolted in a narrow grid
- 8 mm wear layer on the pole plate
- Chucking slots on both face sides
- Length over 1000 mm with through holes for fastening upon agreement
- Robust and water-tight
- Protection rating IP 65
- 100 % duty cycle
- Suitable for connecting to the SAV 876.10 control unit

### RATED HOLDING FORCE

90 N/cm<sup>2</sup>, with  $P = 13\text{ mm}$  pole pitch

110 N/cm<sup>2</sup>, with  $P = 18\text{ mm}$  pole pitch

115 N/cm<sup>2</sup>, with  $P = 25\text{ mm}$  pole

control unit using holding force coding switch

### RATED VOLTAGE, RECOMMENDED

24 V DC up to and including 64 W

110 V DC for all other sizes

### APPLICATION

For universal chucking of workpieces with shape and position tolerances of 0.01 to 0.02 mm.

- For main workpiece axis perpendicular to the pole pitch

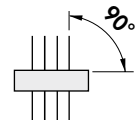

- For workpieces up to min. thickness  $x$ :  
4.5 mm with  $P = 13\text{ mm}$   
6.0 mm with  $P = 18\text{ mm}$   
8.5 mm with  $P = 25\text{ mm}$

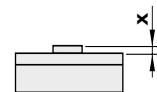

- For flat workpieces min.  $a$ :  
25 mm x 25 mm with  $P = 13\text{ mm}$   
32 mm x 32 mm with  $P = 18\text{ mm}$   
45 mm x 45 mm with  $P = 25\text{ mm}$

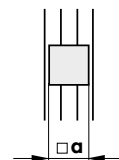

### SCOPE OF DELIVERY

- Stop bar on one short and one long side
- 3 m connecting cable on right short side, rear
- Larger magnetic chucks are provided with lifting lugs for transport
- Control and hand remote unit not in the scope of delivery
- Clamps

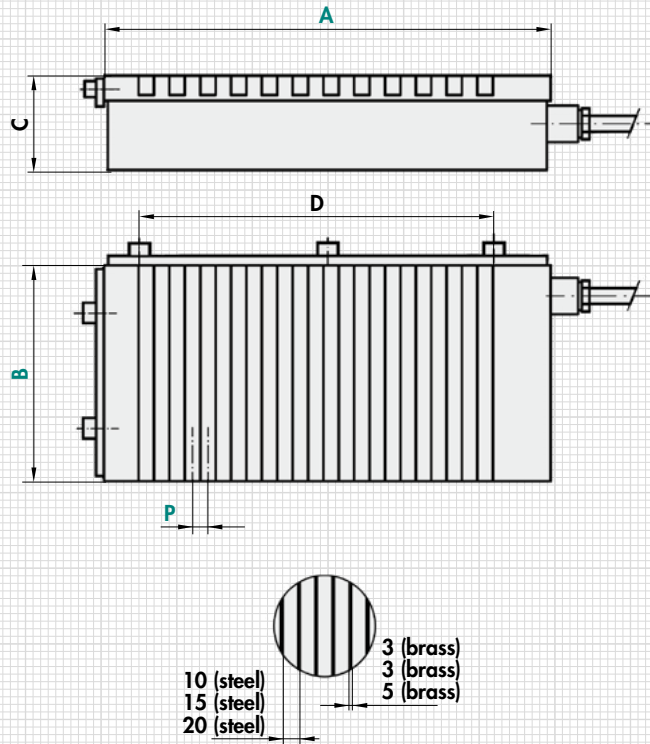

mm					W	kg	Type
A	B	C <sub>0-1</sub>	D	P	Power	Weight	Control
200	100	90	120	13	19	11.0	E 1
300	100	90	224	13	31	17.0	E 1
300	150	90	224	13	42	25.0	E 1
400	150	90	328	13	52	34.0	E 1
450	175	90	380	18	64	44.0	E 1
400	200	90	309	18	66	45.0	E 4
500	200	90	417	18	83	56.0	E 4
600	200	90	525	18	89	67.0	E 4
800	200	90	741	18	120	90.0	E 4
500	250	90	417	18	94	70.0	E 4
600	250	90	525	18	109	84.0	E 4
800	250	90	741	18	127	112.0	E 4
500	300	90	417	18	110	84.0	E 4
600	300	90	525	18	128	101.0	E 4
800	300	90	741	18	171	134.0	E 4
1000	300	90	921	18	209	168.0	E 4
600	350	90	525	18	148	118.0	E 4
800	350	90	741	18	191	157.0	E 4
1000	350	90	921	18	239	196.0	E 4

Other sizes and rated voltages on request. Larger chucking areas can be implemented by joining several blocks without gaps.

mm					W	kg	Type
A	B	C <sub>0-1</sub>	D	P	Power	Weight	Control
600	400	90	525	18	166	134.0	E 4
700	400	90	697	18	187	156.0	E 4
800	400	90	741	18	208	179.0	E 4
1000	400	90	921	18	255	224.0	E 4
1200	400	90	1101	18	329	269.0	E 4
800	500	90	730	25	254	224.0	E 4
1000	500	90	926	25	341	280.0	E 4
1200	500	90	1130	25	374	336.0	E 4
1250	500	90	1180	25	390	350.0	E 4
1500	500	90	1430	25	458	420.0	E 4
1600	500	90	1530	25	489	438.0	E 4
2000	500	90	1930	25	576	560.0	E 4
1000	600	90	930	25	361	382.0	E 4
1200	600	90	1130	25	441	459.0	E 4
1250	600	90	1180	25	459	478.0	E 4
1500	600	90	1430	25	487	573.0	E 4
1600	600	90	1530	25	520	611.0	E 4
2000	600	90	1930	25	607	764.0	E 4
1500	800	90	1430	25	730	764.0	E 5
1600	800	90	1530	25	693	815.0	E 5
2000	800	90	1930	25	810	1018.0	E 5

### RECOMMENDED CONTROL AND CONTROL UNIT

Type	Control	Hand remote unit
E 1	SAV 876.10-S-T-24/7/230	SAV 876.02-SE3
E 4	SAV 876.10-S-O-110/6/230	SAV 876.02-SE3
E 5	SAV 876.10-S-O-110/16/230	SAV 876.02-SE3

Installation control units or for combinations as per page 74.

### ORDERING EXAMPLE

Designation SAV no. - A x B x P - rated voltage  
 Electro magnetic chuck SAV 243.42 - 2000 x 800 - 25 - 110 V