

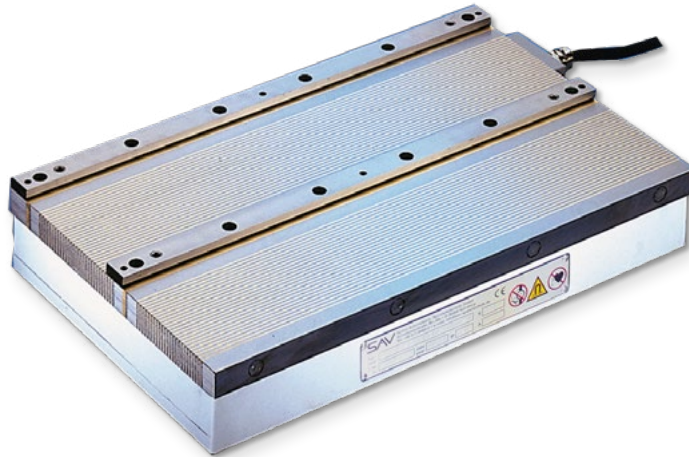

The newly developed workholding system allows workpieces to be reliably pulled against the stop using magnetisable stops. Insertion errors can be prevented with this, particularly in shift operation. Electro permanent magnetic systems with very narrow pole pitch.

The magnetic force is generated by the permanent magnets which are magnetised and demagnetised with short current pulses. Especially suitable for thin parts.



DESIGN

- Design with 2 strong bipolar systems for the stop bar, for reliable alignment of the parts. The stop magnet works at a time offset to the base magnet
- The stop bars are magnetised before the main chucking area. This reliably pulls the workpiece into the lower corner of the stop.
- Pole plate with particularly narrow, continuous longitudinal pole pitch, 3 mm steel and 1 mm brass
- Pole divisions bonded and additionally bolted together solidly with tie rods
- High accuracy thanks to pole plates bolted in a narrow grid
- Switch-off using demagnetising cycle
- 8 mm wear layer on the pole plate
- Low magnetic field height of 4 mm
- Electro-permanent magnetic system for absolute safety in case of power failure
- Chucking slots on both face sides
- Reinforced systems for high wear possible on request
- Length over 1000 mm with through holes for fastening upon agreement
- Robust and water-tight
- Protection rating IP 65

RATED HOLDING FORCE

100 N/cm²,
Controllable with control unit

RATED VOLTAGE, RECOMMENDED

360 V IMP

APPLICATION

Primarily for precise grinding of mass-produced parts, especially in shift operation. For toolmaking, the system allows precision machining to the μ m relative to the reference edge against the stop.

- Magnetically active stops automatically controlled in sequence
- For thin workpieces up to:
min. thickness = 12 mm
(depending on stop height)
- For flat workpieces:
min. width = 40 mm

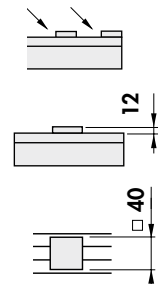

SCOPE OF DELIVERY

- 1 or 2 magnetic stop bars
- 3 m connecting cable on right short side, rear
- On request with water-tight heavy-duty power connector
- Larger magnetic chucks are provided with lifting lugs for transport
- Control and hand remote unit not in the scope of delivery
- Clamps

Controlled by the electronic polarity reversal control unit, the stop bars are magnetised in the first step, causing the workpiece to be reliably pulled into the corner of the stop bar at a 45° angle with force F_A . In the second step, the main chucking area is activated after approx. 1 s, generating the two-dimensional main holding force F_H .

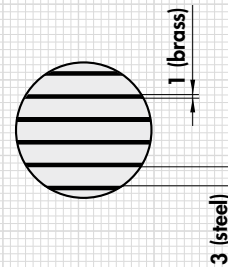
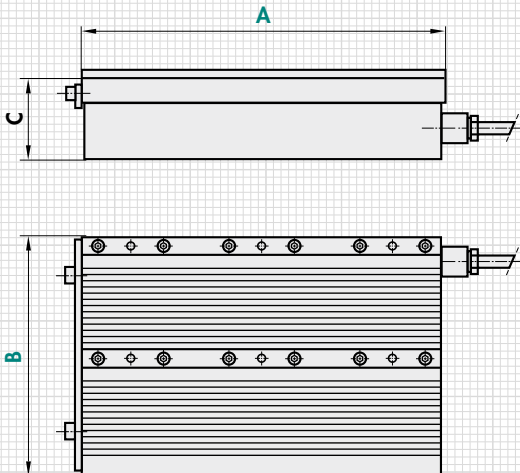
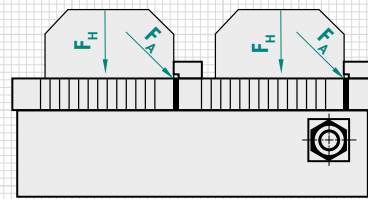

mm				Qty.	kg	A
A	B	C ₁ ⁰	D*	Number of stops	Weight	Control max. pulse current
400	200	77	12	1	45.0	30x2
500	200	77	12	1	56.0	30x2
600	200	77	12	1	67.0	30x2
400	300	77	12	2	68.0	30x2
500	300	77	12	2	86.0	30x2
600	300	77	12	2	103.0	30x2
600	400	77	12	2	137.0	30x2
800	400	77	12	2	183.0	30x2

* Other stop heights on request.
The table provides an overview of the possible sizes. Custom designs and dimensions are always possible. Suitable polarity reversal control units can be found under SAV 876.17.

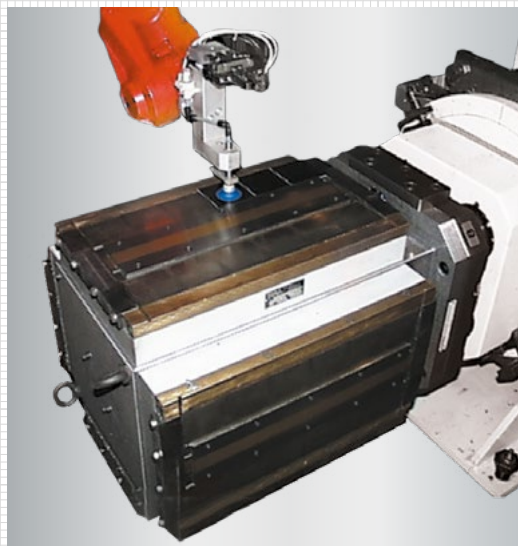

ORDERING EXAMPLE

Designation SAV no. - A x B - rated voltage
Electro permanent magnetic chuck SAV 243.72 - 800 x 400 - 360 V

PERM
1.2.1
E
1.2.2
EP
1.2.3
1.2.4
1.2.5
E
1.2.6
1.2.7
1.2.8
1.2.9
S N S
1.2.10