

SAV 244.10

PERMANENT MAGNETIC CIRCULAR CHUCKS

Controllable



APPLICATION

For manual collet chucks as an auxiliary magnet for chucking small, delicate workpieces. Also suitable for fixtures and as a holding magnet.

DESIGN

Controllable permanent magnet, chucking areas at the top.



mm					N	rpm	kg
A	B ^{+0.5/-2}	C	D	E	Rated force	Max. speed	Weight
50	50	25	35	4 x M5	85	450	0.7
80	65	50	60	4 x M6	500	400	2.2

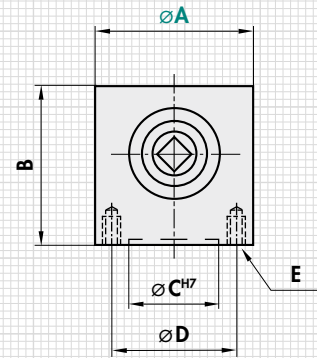

ORDERING EXAMPLE

Designation	SAV no. - A
Permanent magnetic circular chuck	SAV 244.10 - 80

SAV 244.11

PERMANENT MAGNETIC CIRCULAR CHUCKS

With parallel pole pitch, reinforced magnet system



APPLICATION

For chucking small to large workpieces for grinding and turning.

DESIGN

Powerful magnet system with neodymium magnets and low magnetic field height. All sizes with 1 control point. Magnetic force continuously adjustable. Option for integrating a central hole "H". Available with flange on request (see SAV 248.90 to 248.94).

Concentric rings facilitate visual alignment of the workpieces. Pole gap with solid brass.

TECHNICAL DATA

- Rated holding force:
 - Diameter A = 160 and 200 mm: 100 N/cm²
 - Diameter A = 250 to 500 mm: 150 N/cm²
- Magnetic field height: 10 mm
- Wear layer of the pole plate: 6 mm
- Geometrically balanced: G 6.3

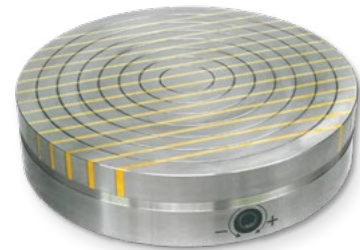

mm										kg
A	B ^{+0.5/-2}	C	D	E	F	G	H	J	P	Weight
160	57	102	125	142	4 x M8	4	12	D15x6	8+3	8.0
200	57	146	150	180	4 x M8	4	12	D20x6	8+3	13.0
250	57	198	200	232	4 x M8	4	12	D25x20	12+3	20.0
300	62	228	250	285	4 x M8	4	12	D25x20	12+3	31.0
350	62	288	300	334	4 x M8	5	12	D25x20	12+3	43.0
400	67	318	300	350	6 x M10	5	20	D25x20	12+3	60.0
450	67	378	350	400	6 x M10	5	20	D25x20	12+3	76.0

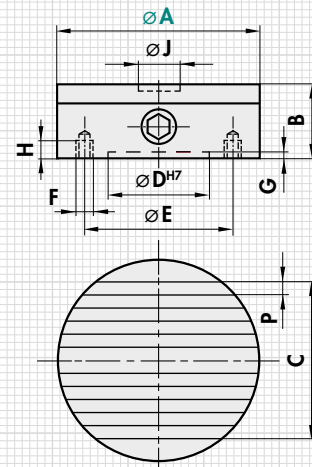

ORDERING EXAMPLE

Designation	SAV no. - A
Permanent magnetic circular chuck	SAV 244.11 - 250