



The circular magnets with circular pole pitch allow several workpieces to be chucked off-centre. The strong magnetic field is distributed evenly across the pole plate.



DESIGN

- Pole pitch manufactured “gap-free”
- Uniform, strong magnetic field
- Solid pole plate
- Switch-off using demagnetising cycle
- Electro permanent magnetic system for absolute safety in case of power failure
- High accuracy thanks to pole plates bolted in a narrow grid
- Pole plate with brass, wear-protected
- Pole plate can be replaced when worn
- 8 mm wear layer on the pole plate
- Protection rating IP 65
- Available with flange on request (see SAV 248.90 to 248.94, chapter 1.2.1)

RATED HOLDING FORCE

100 N/cm², controllable with control unit

RATED VOLTAGE, RECOMMENDED

210 V IMP up to size A = 500

360 V IMP above size A = 500

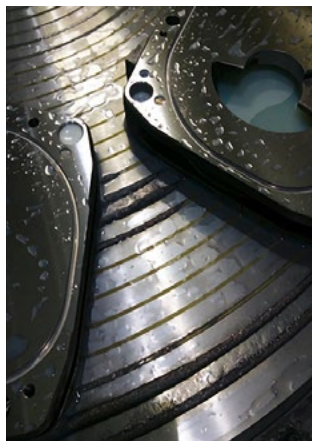

APPLICATION

Primarily for precise grinding of small to large workpieces on rotary table and cylindrical grinding machines. The circular pole pitch also allows machining of multiple parts which are not placed centrally.

- Circular pole pitch ensures even distribution of holding force on the circumference. This makes it suitable for thin, flat parts (e.g. saw blades).



- Placement of multiple parts on pitch circle diameter possible

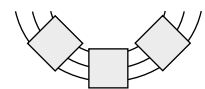

- For workpieces up to min. thickness x:
2 mm with P = 5.5 mm
4 mm with P = 9 mm
8 mm with P = 18 mm

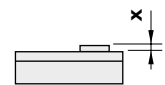

- For flat workpieces:
Min. size = 45 mm x 45 mm

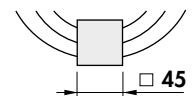

- Not suitable for thin rings

SCOPE OF DELIVERY

- Larger circular magnets are provided with threads for transport
- Standard electrical connection centrally on the rear side using terminals
- Alternatively with integrated flat slip ring assembly for larger diameters from 1000 mm
- Available with water-tight heavy-duty power connector on the outer circumference on request
- Control and hand remote unit not in the scope of delivery

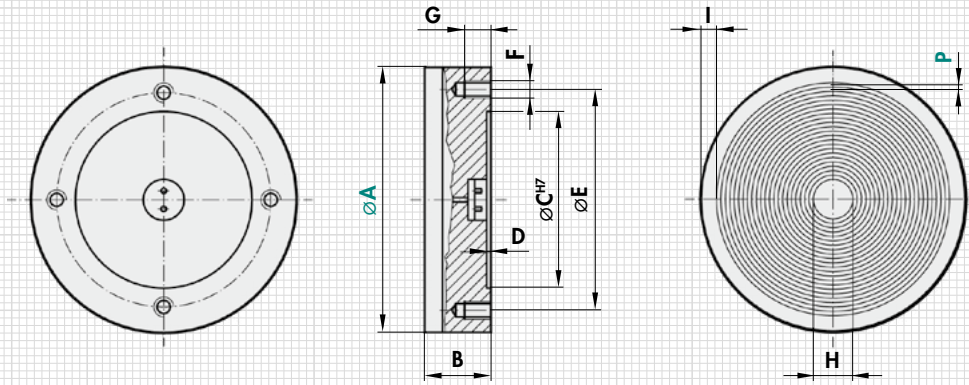

mm										kg	V	A
A	B ₋₁ ⁰	C	D	E	F	G	H	I	P	Weight	Rated voltage	Control max. pul. Current
300	105	160	3	190	M12 (4x)	16	76	16	5,5	52.0	210	30
400	105	210	4	250	M12 (6x)	16	90	21	9	89.0	210	30
500	105	280	4	320	M12 (6x)	16	96	21	9	141.0	210	30
600	105	350	4	390	M12 (6x)	18	80	21	9	204.0	360	30
700	105	400	4	450	M12 (6x)	18	96	21	9	278.0	360	30
800	105	450	4	500	M16 (6x)	18	96	22	9	383.0	360	30
1000	105	550	4	620	M16 (8x)	18	96	22	9	578.0	360	60
400	105	210	4	250	M12 (6x)	16	66	21	18	89.0	210	30
500	105	280	4	320	M12 (6x)	16	92	21	18	141.0	210	30
600	105	350	4	390	M12 (6x)	18	70	21	18	204.0	360	30
700	105	400	4	450	M12 (6x)	18	92	21	18	278.0	360	30
800	105	450	4	500	M16 (6x)	18	92	22	18	383.0	360	30
1000	105	550	4	620	M16 (8x)	18	92	22	18	578.0	360	60
1200	110	Rear side upon agreement				22	80	23	9	990.0	360	60x2
1400	110	Rear side upon agreement				22	166	26	9	1350.0	360	60x2
1500	120	Rear side upon agreement				22	166	26	9	1550.0	360	60x2
1600	120	Rear side upon agreement				22	166	26	9	1765.0	360	60x2
1200	110	Rear side upon agreement				22	70	23	18	990.0	360	60x2
1400	110	Rear side upon agreement				22	166	26	18	1350.0	360	60x2
1500	120	Rear side upon agreement				22	166	26	18	1550.0	360	60x2
1600	120	Rear side upon agreement				22	166	26	18	1765.0	360	60x2

Larger diameters, e.g. 5.5 m, available on request.

Allocation to the correct control unit is based on the max. power consumption, SAV 876.17.



ORDERING EXAMPLE

Designation SAV no. - A - P - rated voltage
 Electro permanent magnetic circular chuck SAV 244.72 - 1600 - 18 - 360 V