

SAV 245.40

PRECISION SINE TABLE

[also stainless version] swivelling around the longitudinal axis



DESIGN

With switchable permanent magnetic chuck block SAV 242.11. With sine table base unit made of steel. Hardened, burnished and precision-ground. Delivered in a wooden storage box with sine table with degrees/minutes in mm. Stainless version (RF) available.

APPLICATION

The angles are determined using the gauge blocks using the sinusoidal principle. The switchable magnetic chuck block can be removed and can therefore also be used without a sine table.

All four chucking areas of the chuck block are magnetically active.

TECHNICAL DATA

- Angle accuracy: ± 5 arc sec
- Plane parallelism: $\pm 0.005/100$ mm
- Gauge block at 0° : 3 mm
- Swivelling range: 0° to 45°
- Rated holding force: 50 N/cm^2
- Rated holding force, stainless: 30 N/cm^2

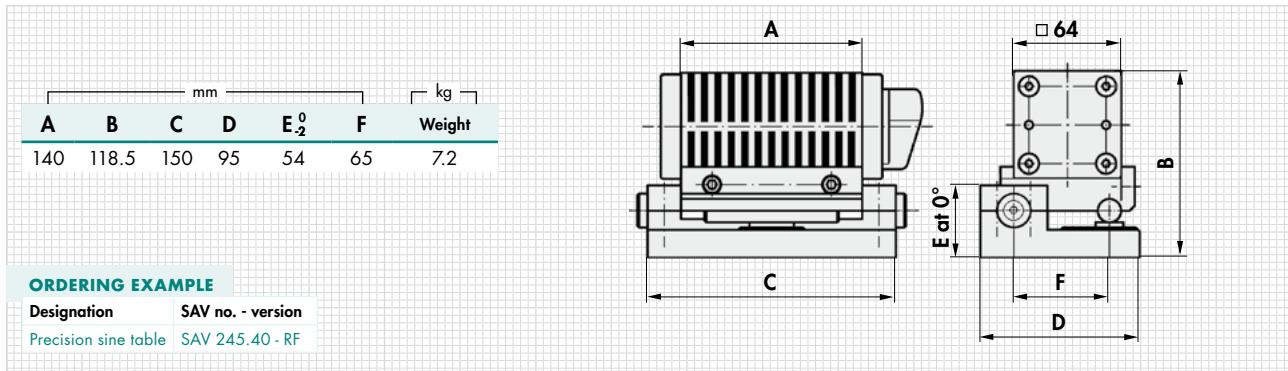
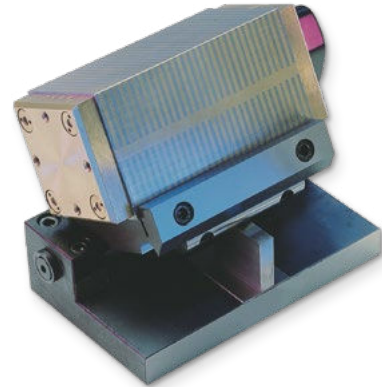

SAV 245.41

PRECISION SINE TABLE

[also stainless version] Swivelling around the transverse axis



DESIGN

With switchable permanent magnetic chuck block SAV 242.11. With sine table base unit made of steel. Hardened, burnished and precision-ground. Delivered in a wooden storage box with sine table with degrees/minutes in mm. Stainless version (RF) available.

APPLICATION

The angles are determined using the gauge blocks using the sinusoidal principle. The switchable magnetic chuck block can be removed and can therefore also be used without a sine table.

All four chucking areas of the chuck block are magnetically active.

TECHNICAL DATA

- Angle accuracy: ± 5 arc sec
- Plane parallelism: $\pm 0.005/100$ mm
- Gauge block at 0° : 3 mm
- Swivelling range: 0° to 45°
- Rated holding force: 50 N/cm^2
- Rated holding force, stainless: 30 N/cm^2

