

SAV 434.05

PRECISION ANGLE DRESSERS

For angled dressing of grinding wheels



APPLICATION

For precise grinding wheel dressing using the sinusoidal principle on surface grinding machines.

DESIGN

All parts hardened HRC 60 and precision-ground.
The starting position of the dressing unit is at 45°.
Angle accuracy: 5 arc sec

ACCESSORIES

Dressing diamonds for SAV 434.05 - 45:
SAV 401.01 - K 10
Dressing diamond for SAV 434.05 - 100:
SAV 401.01 - MK 1
Available subject to a surcharge.

APPLICATION

The desired angle is adjusted with gauge blocks as per a supplied table (sinusoidal principle).



SAV 434.05 - 45
Dressing travel: 45 mm



SAV 434.05 - 100
Dressing travel: 100 mm

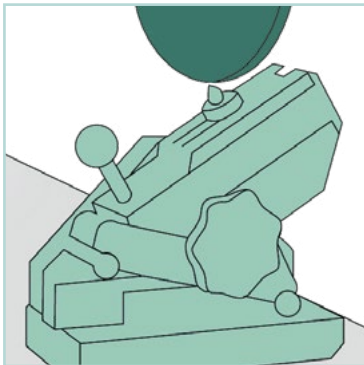

Max. dressing travel A	in mm	45	100
Base area B x C	in mm	140 x 70	245 x 78
Height D – E	in mm	142 - 172	232 - 302
Slide width F	in mm	40	48
Home position	in °	45	45
Total adjustment range	in °	0 - 90	0 - 90
Axis distance G	in mm	100	200
∅ for dressing diamond	in mm	6.2 / 1:10	MK 1
Weight	in kg	4.75	13.5

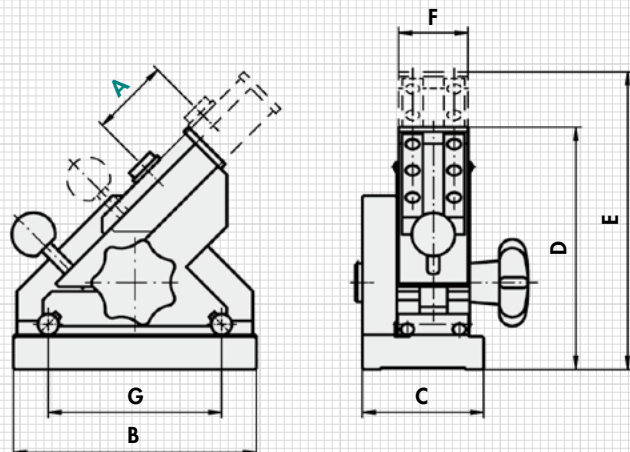

ORDERING EXAMPLE

Designation	SAV no. - max. dressing travel
Precision angle dresser	SAV 434.05 - 100