

**DESIGN**

With sine table base units made of steel. Hardened, burnished and precision-ground. Maximum precision with flat design. Standard design with permanent magnetic chuck.

Delivered in a wooden storage box.

With 2 sine tables with degrees/minutes in mm, precision length stop and transverse stop bar.

APPLICATION

The angles are determined using the gauge blocks using the sinusoidal principle.

Clamping is achieved with a fastening brace at the side and the upper bearing shells.

TECHNICAL DATA

- Angle accuracy: ± 5 arc sec
- Plane parallelism: $\pm 0.005/100$ mm
- Gauge block at 0° : 3 mm
- Swivelling range, long axis: 0° to 45°
- Swivelling range, short axis: 0° to 30°
- Rated holding force: 90 N/cm^2
- Pole pitch: 1.9 mm
- Magnetic field height: 6 mm
- Wear layer of the pole plate: 8 mm

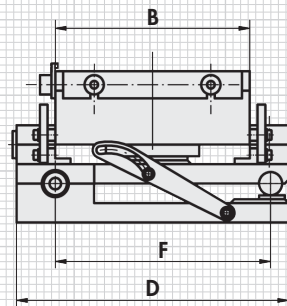
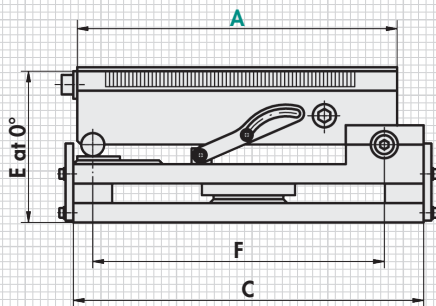
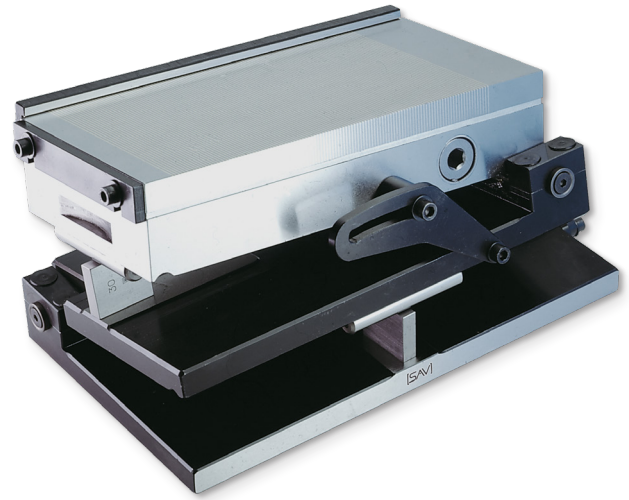

| mm | | | | | | kg |
|-----|-----|-----|-----|---------|-----------|--------|
| A | B | C | D | E_2^0 | F | Weight |
| 175 | 100 | 210 | 140 | 108 | 160 / 115 | 15.0 |
| 255 | 130 | 290 | 175 | 112 | 240 / 145 | 32.0 |
| 300 | 150 | 335 | 190 | 117 | 285 / 160 | 43.5 |
| 350 | 150 | 385 | 190 | 117 | 335 / 160 | 49.5 |
| 400 | 200 | 435 | 240 | 117 | 385 / 210 | 73.0 |

Other designs and dimensions on request. Also available with electro permanent magnet or other magnet systems.

All standard sized of the permanent magnetic chucks SAV 243.01 (chapter 1.2.1) are available as a sine table.

Available with flushing hole for EDM on request (surcharge applies).

ORDERING EXAMPLE

| | |
|----------------------|------------------|
| Designation | SAV no. - A |
| Precision sine table | SAV 245.02 - 400 |